



BEVERAGE-AIR

Project: _____	AIA#
Item: _____	
Location: _____	SIS#
Approved: _____	

COUNTERTOP MERCHANDISER SERIES

CF3HC Countertop Freezer
Hydrocarbon Series

MODEL:
CF3HC-1-W

CF3HC COUNTERTOP FREEZER

1 Year Parts/Labor Warranty



CABINET CONSTRUCTION

- Pre-painted steel exterior
- Interior white painted steel for easy cleaning
- Triple pane glass
- Two (2) shelves standard, adjustable one full and one half shelf
- Unit standard with leveling legs which are 2" high, legs can be adjusted up to 1" for leveling of the freezer
- LED lighting

OPTIONS & ACCESSORIES

- Custom graphics

REFRIGERATION SYSTEM

- Refrigeration system uses R290 refrigerant to comply with all environmental concerns
- Cold wall evaporator
- The unit is best suited for an environment where temperatures remain below 75°F and humidity does not exceed 55%
- Freezer operating temperature is 0°F to -10°F



Please verify qualifying units by visiting:
www.energystar.gov/cfs

3779 Champion Blvd., Winston-Salem, NC 27105
1-888-845-9800 Fax: 1-336-245-6453
Beverage-Air.com Sales@bevair.com



BEVERAGE-AIR.

MODEL	CF3HC-1-W
EXTERNAL DIMENSIONAL DATA	
Width Overall	23.7"
Depth Overall	23.9"
Height Overall (excludes leveling legs)	29.2"
Number of Doors	1
INTERNAL DIMENSIONAL DATA	
NET Capacity (cubic ft.)	2.9
Number of Shelves	2
ELECTRICAL DATA	
Full Load Amperes 120/60/1	3.5
REFRIGERATION DATA	
Horsepower	1/4
WEIGHT DATA	
Gross Weight (Crated lbs)	120 lbs
Height - Crated	33"
Width - Crated	26"
Depth - Crated	26"

Countertop Freezer Model: CF3HC-1-W

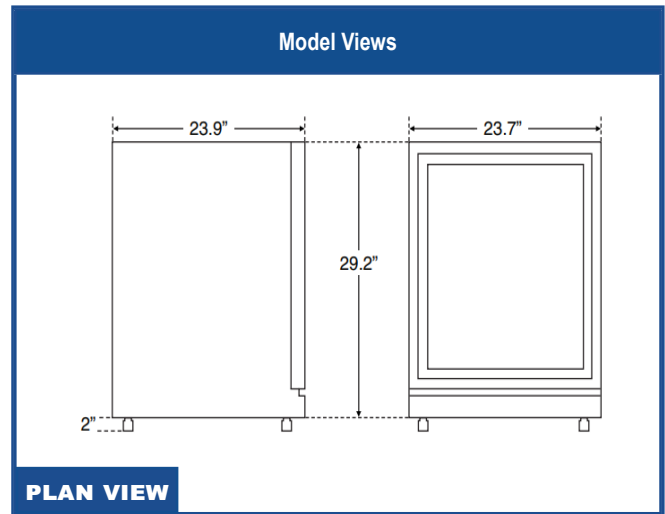

ELECTRICAL CONNECTION



120/60/1
NEMA 5-15P

Unit pre-wired at factory
and include cord and
plug set.